



EXPERIENCE THE EXCEPTIONAL

# BSAI™ & BSAIG™

## Metal Bellows Component Seal



- 12 bellows convolutions as standard
- Alloy 276 standard bellows material
- Hydraulically balanced seal face design
- Modular construction for maximum flexibility
- Available with elastomer or graphite ring
- Easy reliable installation



# BSAI™ Metal Bellows Component Seal

The main benefit of using a metal bellows seal is the removal of the semi-dynamic sliding elastomer from a conventional pusher type seal. This means that bellows seals can be used where chemical attack on this elastomer is a problem.



## Major advantages of using AESSEAL® Metal Bellows Seals

- 50% more bellows than the industry standard means there is less stress on each convolution in the bellows stack which helps increase seal life. It is for this reason that this seal is more able to accommodate installation tolerances and will maintain a more consistent face pressure as the seal wears in use
- Finite Element Analysis was used to optimise the bellows convolution profile on its inside diameter at 45° which means minimal stress on the weld beads
- The standard bellows material, Alloy 276, has superior mechanical and corrosion resistance properties compared to other industry standard bellows materials such as 300 series Stainless Steel or Alloy 20. The seal face holder and drive end are inventoried as standard in 316L Stainless Steel

# BSAI™ Component Seals with Elastomer Options

## BSAI™ Design Features

The seal is offered with the following features:

- Hydraulically balanced seal face design
- Short internal working length
- Patented modular rotary seal head
- No shaft fretting
- Excellent general service seal
- Fits 0.3125" (8mm) cross section to suit shaft sizes up to and including 1.375" (35.0mm)
- 12 Convolute Alloy 276 bellows as standard



## Imperial BSAI™

Sizes available & generally inventoried: 1.000" - 4.000"

The BSAI™ range is available in a wide range of seal face and elastomer combinations, together with self-aligning, DIN, CURC™, T, L shaped or boot mounted stationaries.

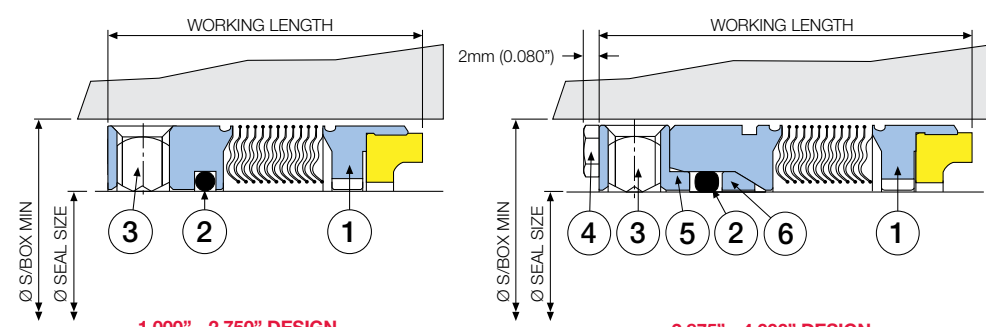

1.000" - 2.750" DESIGN

2.875" - 4.000" DESIGN

ITEM	DESCRIPTION	MATERIAL
1	Rotary Bellows Assembly	316L SS - Alloy 276 - 316L SS - Carbon/TC/SiC
2	Sealing Ring	Viton® / EPR / Kalrez® / Atlas®
3	Drive Screws	Stainless Steel
4	Rotary Drive Screws	Stainless Steel
5	Clamp Ring	316L Stainless Steel
6	Spacer Ring	316L Stainless Steel

## BSAI™ size chart (inches)

SEAL SIZE	WORKING LENGTH	S/BOX MIN
1.000	1.250	1.625
1.125	1.250	1.750
1.250	1.312	1.875
1.375	1.437	2.000
1.500	1.437	2.125
1.625	1.437	2.250
1.750	1.437	2.375
1.875	1.500	2.500
2.000	1.500	2.625
2.125	1.500	2.750
2.250	1.562	2.875
2.375	1.562	3.000
2.500	1.562	3.125
2.625	1.625	3.375
2.750	1.625	3.500
2.875	1.875	3.625
3.000	2.000	3.750
3.125	2.000	3.875
3.250	2.000	4.000
3.375	2.000	4.125
3.500	2.000	4.250
3.625	2.000	4.375
3.750	2.000	4.500
3.875	2.000	4.625
4.000	2.000	5.000

## DIN BSAI™

- Any non inventoried DIN BSAI™ seal size can be made to order
- The metric BSAI™ seals conform to BS EN 12756 (formerly DIN 24960) when used in conjunction with an AESSEAL® DIN stationary
- Full Alloy 276 BSAI's inventoried in the following sizes

**Sizes available:** Most imperial and metric sizes can be made to order.

**Sizes inventoried -** 1.125", 1.250", 1.375", 1.500", 1.625", 1.750", 1.875", 2.000", 2.125", 2.375", 2.500", 2.750", 3.500". (25mm, 30mm, 32mm, 33mm, 35mm, 38mm, 40mm, 43mm, 45mm, 48mm, 60mm, 85mm, 100mm).

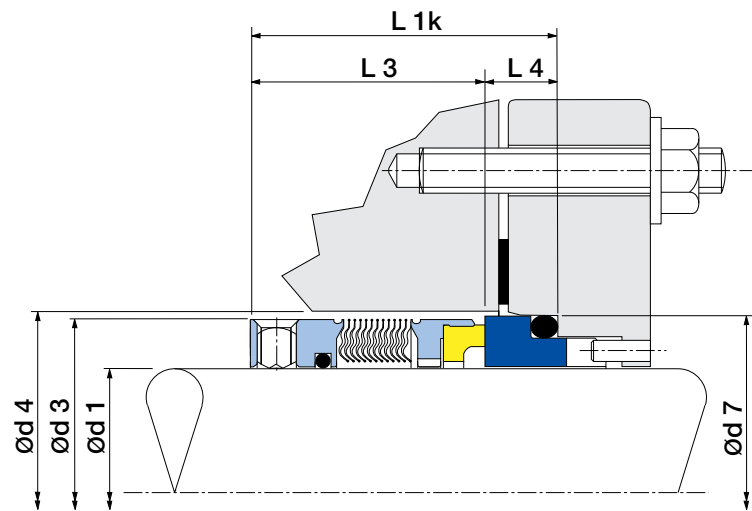

**Sizes available:** Ø24mm - Ø100mm

**Sizes inventoried -** Popular metric shaft sizes including 33mm, 35mm, 43mm, 45mm, 53mm and 55mm.

Standard seals are inventoried in 316L S/S for the drive end & face holder with an Alloy 276 bellows stack. Other materials are available on request.

**DIN BSAI™ size chart (mm)**

Ød1 h6	L3	L1k +/- 0.5	L4	Ød7 H8	Ød3 MAX	Ød4 MIN
24.0	29.9	40.0	10.1	39.0	38.0	40.0
25.0	29.9	40.0	10.1	40.0	39.0	41.0
28.0	32.4	42.5	10.1	43.0	42.0	44.0
30.0	32.4	42.5	10.1	45.0	44.0	46.0
32.0	32.4	42.5	10.1	48.0	46.0	48.0
33.0	32.4	42.5	10.1	48.0	47.0	49.0
35.0	32.4	42.5	10.1	50.0	49.0	51.0
38.0	33.9	45.0	11.1	56.0	54.0	58.0
40.0	33.9	45.0	11.1	58.0	56.0	60.0
43.0	33.9	45.0	11.1	61.0	59.0	63.0
45.0	33.9	45.0	11.1	63.0	61.0	65.0
48.0	33.9	45.0	11.1	66.0	64.0	68.0
50.0	34.4	47.5	13.1	70.0	66.0	70.0
53.0	34.4	47.5	13.1	73.0	69.0	73.0
55.0	34.4	47.5	13.1	75.0	71.0	75.0
58.0	38.9	52.5	13.6	78.0	78.0	83.0
60.0	38.9	52.5	13.6	80.0	80.0	85.0
63.0	38.9	52.5	13.6	83.0	83.0	88.0
65.0	38.9	52.5	13.6	85.0	85.0	90.0
68.0	37.4	52.5	15.1	90.0	88.0	93.0
70.0	44.9	60.0	15.1	92.0	90.0	95.0
75.0	44.9	60.0	15.1	97.0	99.0	104.0
80.0	44.2	60.0	15.8	105.0	104.0	109.0
85.0	44.2	60.0	15.8	110.0	109.0	114.0
90.0	49.2	65.0	15.8	115.0	114.0	119.0
95.0	49.2	65.0	15.8	120.0	119.0	124.0
100.0	49.2	65.0	15.8	125.0	124.0	129.0

## BSAIG™ Component Seals with Graphite Packing

The BSAIG™ component seal with graphite packing employs the standard rotary unit in the AESSEAL® modular seal range.

**The seal is offered with the following features:**

- Hydraulically balanced seal face design
- No shaft fretting
- High performance single component seal
- Fits 0.3125" (8mm) cross section to suit shaft sizes up to and including 1.375" (35.0mm)
- Graphite packing with excellent chemical resistance

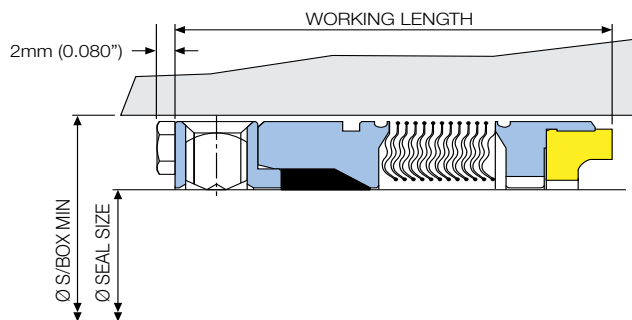

**BSAIG™ size chart (Inches)**

SEAL SIZE	WORKING LENGTH	S/BOX MIN
1.000	1.500	1.625
1.125	1.500	1.750
1.250	1.500	1.875
1.375	1.500	2.000
1.500	1.688	2.125
1.625	1.688	2.250
1.750	1.688	2.375
1.875	1.688	2.500
2.000	1.688	2.625
2.125	1.688	2.750
2.250	1.688	2.875
2.375	1.688	3.000
2.500	1.688	3.125
2.625	1.875	3.375
2.750	1.875	3.500
2.875	2.000	3.625
3.000	2.000	3.750
3.125	2.000	3.875
3.250	2.000	4.000
3.375	2.000	4.125
3.500	2.000	4.250
3.625	2.000	4.375
3.750	2.000	4.500
3.875	2.000	4.625
4.000	2.000	5.000

**BSAIG™ size chart (mm)**

SEAL SIZE	WORKING LENGTH	S/BOX MIN
24	38.1	40
25	38.1	41
28	38.1	44
30	38.1	46
32	38.1	48
33	38.1	49
35	38.1	51
38	42.9	58
40	42.9	60
43	42.9	63
45	42.9	65
48	42.9	68
50	42.9	70
53	42.9	73
55	42.9	75
58	42.9	78
60	42.9	80
63	42.9	83
65	47.6	89
68	47.6	92
70	47.6	94
75	50.8	99
80	50.8	104
85	50.8	109
90	50.8	114
95	50.8	119
100	50.8	125

**Sizes available:** Most imperial and metric sizes can be made to order.

**Sizes inventoried -** 1.125", 1.375", 1.500", 1.625", 1.750", 1.875", 2.000", 2.125", 2.500", 2.625", 2.750", 2.875", 3.000", 3.500". (25mm, 32mm, 33mm, 35mm, 40mm, 43mm, 60mm).

# BSAI™ - Metal Bellows Component Seal

To compliment the BSAI™ range, AESSEAL® have an extensive range of seats available.

For more information please see the SAICSNCESEAT product range brochure.

T-SEAT™



L-SEAT™



O-SEAT™



DIN-SEAT™



AESSEAL® also produce a range of single and double cartridge mechanical seals using the same modular Metal Bellows technology. The main products in this range are the BQFD™, BCFG™ and BDFI™ which all have their own brochure which can be requested from AESSEAL®.



These brochures can be downloaded from the AESSEAL® website at [www.aesseal.com](http://www.aesseal.com) or copies can be requested by email from [marketing@aesseeal.com](mailto:marketing@aesseeal.com).

This document is designed to provide dimensional information and an indication of availability. For further information and safe operating limits contact our technical specialists at the locations below.



Use double mechanical seals with hazardous products.

Always take safety precautions:

- Guard your equipment
- Wear protective clothing

**WARNING**

**UK Sales & Technical advice:**

AESSEAL plc  
Mill Close  
Bradmarsh Business Park  
Rotherham, S60 1BZ  
United Kingdom

Tel: +44 (0) 1709 369966  
Fax: +44 (0) 1709 720788  
E-mail: [seals@aesseeal.com](mailto:seals@aesseeal.com)  
[www.aesseal.com](http://www.aesseal.com)

Distributed by:

'Our purpose is to give our customers such exceptional service that they need never consider alternative sources of supply.'



**USA Sales & Technical advice:**

AESSEAL Inc.  
355 Dunavant Drive  
Rockford,  
TN. 37853  
USA

Tel: +1 865 531 0192  
Fax: +1 865 531 0571  
E-mail: [usa@aesseeal.com](mailto:usa@aesseeal.com)  
[www.aesseal.com](http://www.aesseal.com)

Important: Since the conditions and methods of use of this product are beyond our control, AESSEAL plc expressly disclaims any and all liability resulting or arising from any use of this product or reliance on any information contained in this document - AESSEAL plc standard conditions of sale apply. All sizes are subject to manufacturing tolerances. We reserve the right to modify specifications at any time. AESSEAL® is a Registered Trademark of AESSEAL plc, AESSEAL plc recognizes all trademarks and trademark names as the property of their owners.