



Pre-Installation Checks.

- (i) Shaft Outside Diameter is within tolerance $\pm 0.002"$ ($\pm 0.05\text{mm}$)
- (ii) Housing bore is nominal size $\pm 0.001"$ ($\pm 0.025\text{mm}$).
- (iii) Shaft run out $< 0.010"$ (0.25mm) T.I.R.
- (iv) Shaft end float $< 0.010"$ (0.25mm).
- (v) There are no sharp edges over which the seal 'O' Ring (2,8) and 'O' Ring (7) must pass. Break all sharp edges. Pay special attention to keyways, shaft steps and housing bore edges.
- (vi) Clean and degrease the shaft and housing bore.
- (vii) Lightly grease the shaft and shaft 'O' Ring (2,8) with the lubricant provided (P-80 lubricant ONLY)
- (viii) Check that the o-ring (2,8) position sits on a unmarked area of the shaft.
- (ix) Ensure shaft & housing surface finish is better than $32\mu"$ CLA (0.8 μm Ra) at elastomer position 2, 7 & 8.

Installation instructions.

The following installation instructions may vary, depending on the equipment configuration. Therefore use them as a guideline only.

1. Press the LabTecta®66 seal into the bearing housing plate. This plate is typically separate to the bearing housing. Note: Use a hydraulic press if available. The force from the press should be concentric to the plate bore. Avoid using grease on the housing. Always position outlet ports 'x' and 'y' at the 6 o'clock position as shown.
2. Slide the seal and housing plate assembly into the running position, on the shaft.
3. Secure the housing plate onto the bearing chamber.
4. Assemble rest of equipment in final running position.
5. Remove setting clips (12)
6. Fill the bearing housing with an appropriate fluid, to the OEM/suppliers recommended fluid level.
7. Spin the shaft by hand. Listen and feel for any shaft binding, etc.

Use the provided lubricant (P-80 ONLY) to grease the shaft and shaft 'O' Rings (2,8)

Do not hit the seal. The outer housing is a slight interference fit with the nominal housing bore. If in doubt, use a press to install the LabTecta®66 into the equipment housing plate.

The following installation guide is applicable to all types of rotating equipment however is specifically focused at PUMPS.

In AESSEAL® experience, following this guideline will prolong your equipment life.

- **LASER ALIGN SHAFT AND COUPLING**
- **USE SYNTHETIC BEARING LUBRICANT WHERE EVER POSSIBLE HOWEVER CHECK THE SEALED FLUID COMPATIBILITY FIRST!!!**
- **FIT A CARTRIDGE SEAL AND SYSTEM.**
- **ENSURE PUMP HYDRAULICS STABLE.**
- **REMOVE ANY PIPE STRAIN.**

The LabTecta®66 bearing isolator incorporates the latest labyrinth technology for containing oil and repelling water under SPLASHED conditions. It is NOT designed for use in either horizontal or vertical applications that are flooded with oil or other liquid.

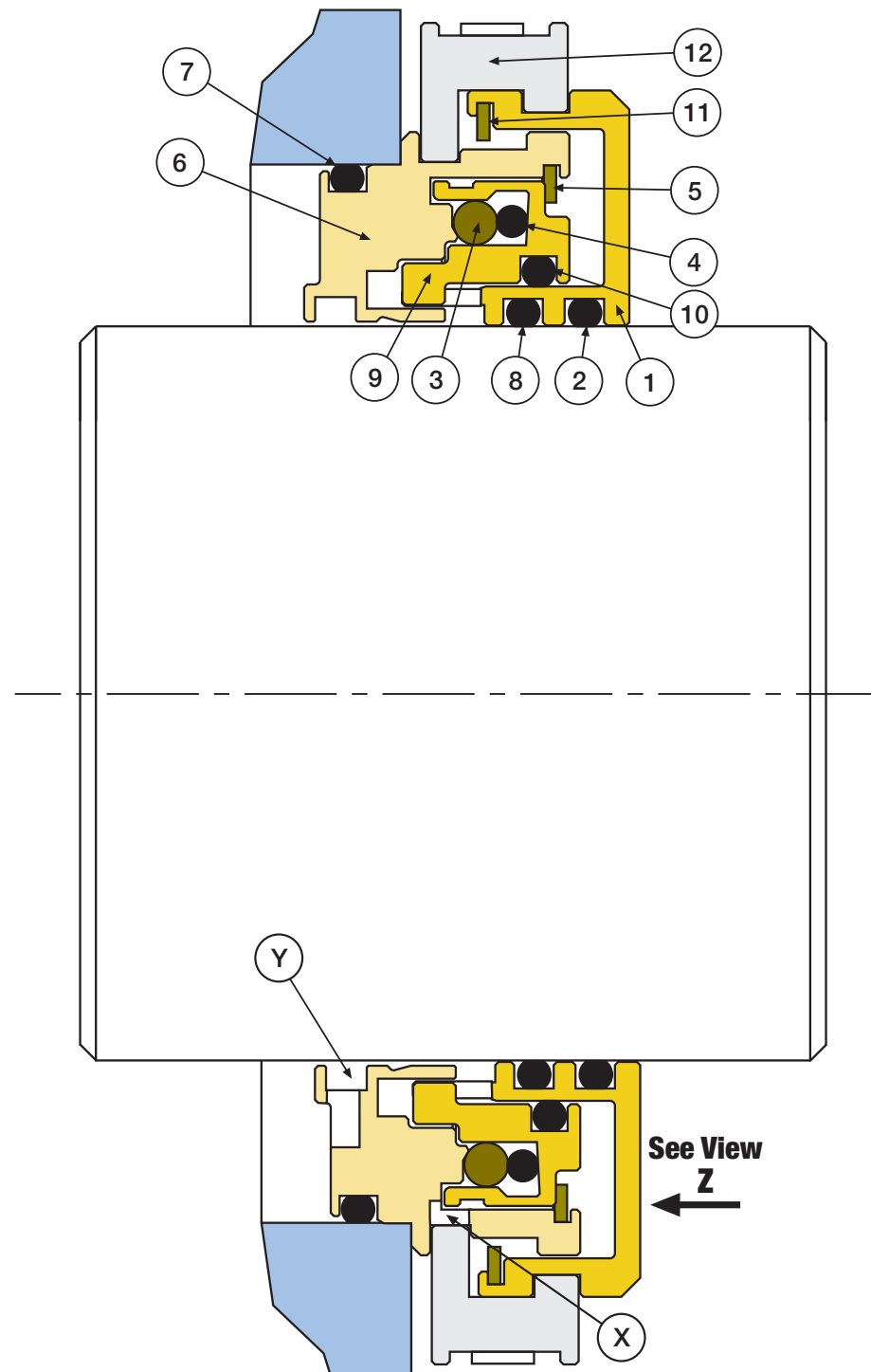

View Z

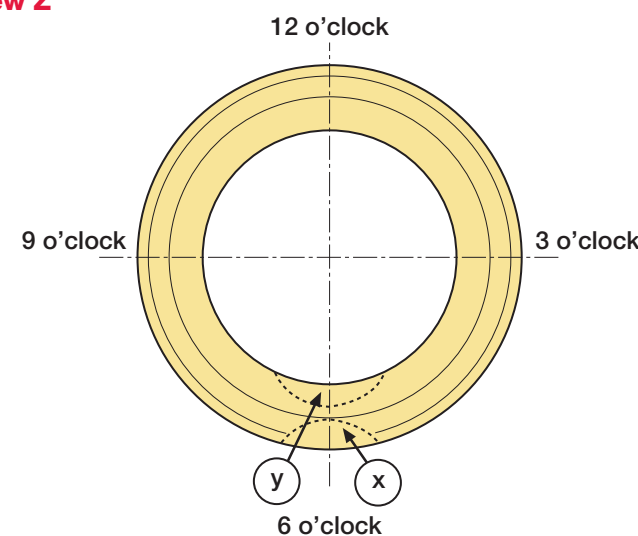

ITEM	DESCRIPTION	MATERIAL
1	LabTecta®66 Rotary	Phosphor Bronze
2	Outboard Rotor O-Ring	Viton®
3	Arknian™ Shut Off Device	Compound Elastomer
4	Arknian™ Energizer	Viton®
5	Face Shield	Composite Material
6	Stator Housing	Phosphor Bronze
7	Stator Housing O-Ring	Viton®
8	Inboard Rotor O-Ring	Viton®
9	Internal Rotary	Phosphor Bronze
10	Internal Rotary O-Ring	Viton
11	Face Shield	Composite Material
12	Setting Clip	Plastic



LabTecta®66AX

Labyrinth Bearing Protector

INSTALLATION INSTRUCTIONS

AESSEAL plc
 Mill Close, Bradmarsh Business Park
 Rotherham S60 1BZ
 ENGLAND
 email info@aes seal.co.uk
 tel +44 (0) 1709 369966
 fax +44 (0) 1709 720788
www.aes seal.com