



EXPERIENCE THE EXCEPTIONAL

CDPH™

Mining & Mineral Ore Medium / Heavy-Duty
Double Slurry Seal



- Double seal suitable for all mining and mineral ore production applications
- Seal face technology designed to accommodate process upsets
- Robust construction designed for ease of installation
- Upgrade service from OEM or non-AESSEAL® seals
- Rapid delivery on engineered customized designs

www.aesseal.com

Slurry Sealing – Over Two Decades of Sealing Expertise

AESSEAL® has been successfully sealing slurries for decades throughout all industries including:

- Mining & Mineral Extraction: Cutting Heads and Conveying
- Pulp & Paper: Black Liquor, Coatings and Medium / High-Duty Stock Processing
- Power Generation: Flue Gas Desulphurization / Scrubbers and Coal Slurry
- Waste Water Production: Macerators and Digested Sludge
- Textiles: Dye Liquors and Fibrous Slurries
- Off-Shore Production: Sand / Gravel Oil Extraction
- Building Services: Asphalt, Pitch, Sand and Cement

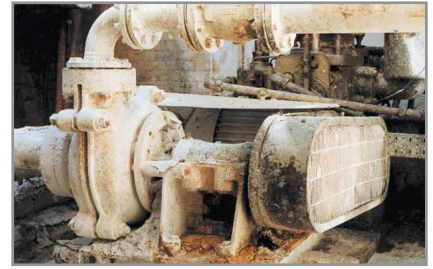

AESSEAL® installed seal on a paper stock pump

Over the years, AESSEAL® has sealed nearly ALL major slurry equipment types and models. Solutions for some of the more commonly encountered manufacturers include Warman, Denver Orion, Goulds and KSB.

Our wide range of seal support systems and bearing protectors complement the mechanical seal range, enabling the supply of TOTAL packaged solutions to improve reliability in all slurry applications.

Successful Sealing – Change the Seal Environment

Not all sealing solutions are the same. Equipment reliability improvements can be made by changing the seal environment and / or upgrading the seal design.

AESSEAL® can provide inexpensive seal conversion kits to upgrade non-AESSEAL® seal designs or to change the OEM equipment seal environment in order to dramatically improve seal life.

- Creates an ideal seal environment
- Produced in a wide range of abrasion / chemical resistant materials
- One-off purchase
- No primary equipment / shaft wear



Conversion Kit for ABS™ Scan pump with integral vortex breaker

AESSEAL® offers a full repair service for most of the common slurry seals found on the market today which includes:

- The supply of new faces in silicon carbide and / or tungsten carbide;
- Replicated exotic alloy metallic components; and
- Metal recovery spraying of worn seal areas, particularly the seal carrier

Seal support systems save water consumption and the environment by reducing or eliminating seal / gland water.

AESSEAL® has a wide range of environmental seal support systems to change the sealing environment to maximize the performance of the mechanical seal.

“AESSEAL® support systems save over **95 Billion Litres / 25 Billion US Gallons** of water per year...”



FLOWTRUE™ units allow the user to monitor and regulate the flow at the seal faces



PUMPPAC™ Range - High-duty self-contained forced lubrication system available in oil and water formats

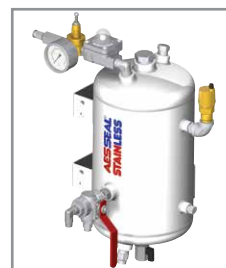

SW2™ Water Management System



One of over 70 AESSEAL® slurry seals and SSE-25™ systems installed at SQM Mining, Chile

CDPH™ – Double Cartridge Seal for Medium / Heavy-Slurry Duties

The CDPH™ double seal is designed to meet the arduous requirements of slurry applications. Large ports and increased radial clearances enable the seal, when coupled with the correct sealing plan, to maintain a stable fluid film for extended seal face life.

Shaft Size*†	up to 9.000" (220mm)
Face Materials	Carbon, Silicon Carbide and Tungsten Carbide
Elastomer Options	Viton®, EPR, Nitrile, Kalrez® & Alfas®

* Not all sizes inventoried, not all metallurgies may be offered in all sizes. Contact your nearest AESSEAL® office for availability.

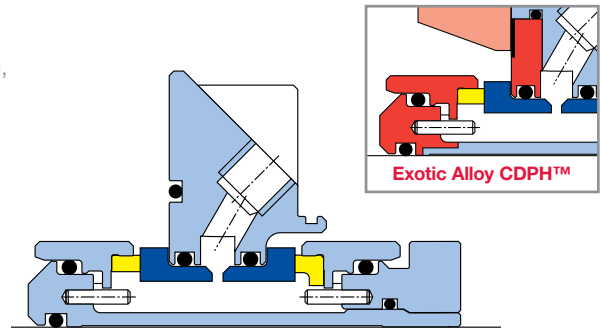

CDPH™ - Double Cartridge Seal

Design Feature	Customer Benefit
Inboard reverse seal face balance	Seal faces will withstand process / system upset ✓
Generally available in 316L Stainless Steel, DIN 1.4462 Duplex, Alloy 255 and Alloy C276†	Improved abrasion and erosion resistance create seal life longevity ✓
Metal to metal fits	Improved alignment and seal performance ✓
Robust drive mechanisms (non-elastomeric)	Reduced possibility of seal face damage ✓
Large radial clearances and non-clogging multi-spring design	Improved seal face loading increases seal life ✓
No flush port / connection	Removes the need for constant seal service water ✓
Hydraulically balanced seal faces	Reduced seal face heat generation and improved life ✓

† Exotic materials may not be available in larger sizes. Other sizes and / or materials may be offered subject to review & approval by AESSEAL® technical department.

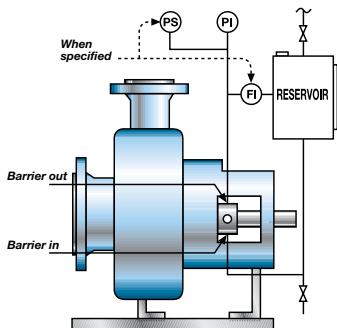

API Plan No.53A

(without pumping ring) Pressurized Barrier Fluid Reservoir Barrier pressure is greater than product pressure

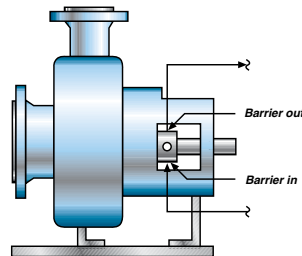

API Plan No.54

Pressurized External Barrier Fluid, normally with a separate pumped system (e.g. PUMPPAC™)

AESSEAL® CDPH™ slurry seal designs suit a wide range of slurry pumps:

Size	50mm				60mm				85mm				100mm				5"				7"									
	Pressure bar				Pressure bar				Pressure bar				Pressure bar				Pressure bar				Pressure bar									
	5	10	15	20	25	5	10	15	20	25	5	10	15	20	25	5	10	15	20	25	5	10	15	20	25	5	10	15	20	25
1,000 rpm																														
1,300 rpm																														
1,800 rpm																														
2,750 rpm																														
3,200 rpm																														

CDPH™ - Seal Selection

- Meets the required PV limits
TC / TC // TC / Carbon
- Check actual speed with technical
- Cooling coil recommended
- Above recommended PV limits
see AESSEAL® technical dept

Single Cartridge Seals – Low / Medium-Duty Range

AESSEAL® has a comprehensive product range to seal slurries including Vulcanized Spring Disk single cartridge seals and multi-spring monolithic seal face designs. The CVSD™ and FGDSS™ range of single cartridge seals are shown below.

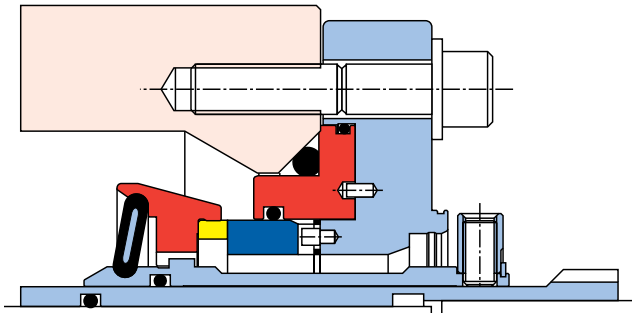

CVSD™ Cross Section

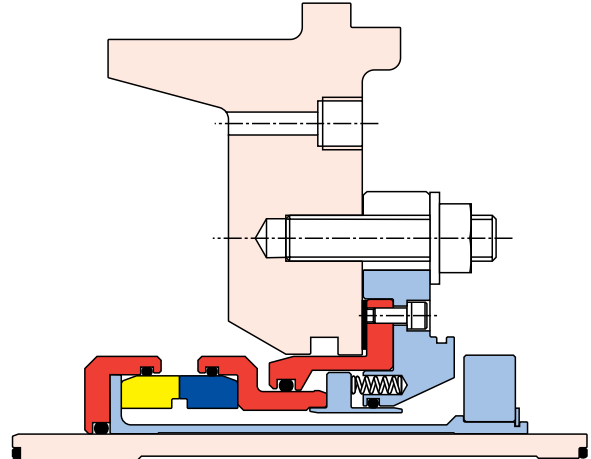

Exotic Alloy FGDSS™ Cross Section

Bearing Protection – Eliminate over 50% of rotating equipment failures

Typically, wherever there is slurry there is also abrasive dust that works its way into the bearings of the rotating equipment. The LabTecta® product family has been shown to eliminate the cause of 52% of bearing failures.

AESSEAL® is a world leader in bearing seal technology and has a proven product range to seal all types of aggressive environments, specifically those synonymous with sealing slurries.

Visit www.LabTecta.com for a 3 minute overview video.



LabTecta® installed on a Falk gearbox

Applications

- Conveyor sealing
- Pillow block sealing
- Gearbox sealing
- Electric motor sealing
- Pump & agitator sealing
- Fans and blower sealing

Bearing Seal Designs

- Contact seal designs
- Non-contact seal designs
- Designs which accept angular misalignment
- Designs which accept axial shaft movement
- Split seal designs
- Air purge designs



LabTecta-OAP-PB™ installed on mining conveyor belt

This document is designed to provide dimensional information and an indication of availability. For further information and safe operating limits contact our technical specialists at the locations below.



Use double mechanical seals with hazardous products.

Always take safety precautions:



- Guard your equipment
- Wear protective clothing

UK Sales & Technical advice:

AESSEAL plc
Mill Close
Bradmarsh Business Park
Rotherham, S60 1BZ
United Kingdom

Tel: +44 (0) 1709 369966

Fax: +44 (0) 1709 720788

E-mail: seals@aes seal.com

www.aes seal.com

Distributed by:

'Our purpose is to give our customers such exceptional service that they need never consider alternative sources of supply.'



USA Sales & Technical advice:

AESSEAL Inc.
355 Dunavant Drive
Rockford,
TN. 37853
USA

Tel: +1 865 531 0192

Fax: +1 865 531 0571

E-mail: usa@aes seal.com

www.aes seal.com

Important: Since the conditions and methods of use of this product are beyond our control, AESSEAL plc expressly disclaims any and all liability resulting or arising from any use of this product or reliance on any information contained in this document - AESSEAL plc standard conditions of sale apply. All sizes are subject to manufacturing tolerances. We reserve the right to modify specifications at any time. AESSEAL® is a Registered Trademark of AESSEAL plc, AESSEAL plc recognizes all trademarks and trademark names as the property of their owners.