

CDMSC™

Cartridge Double Mixer Seal

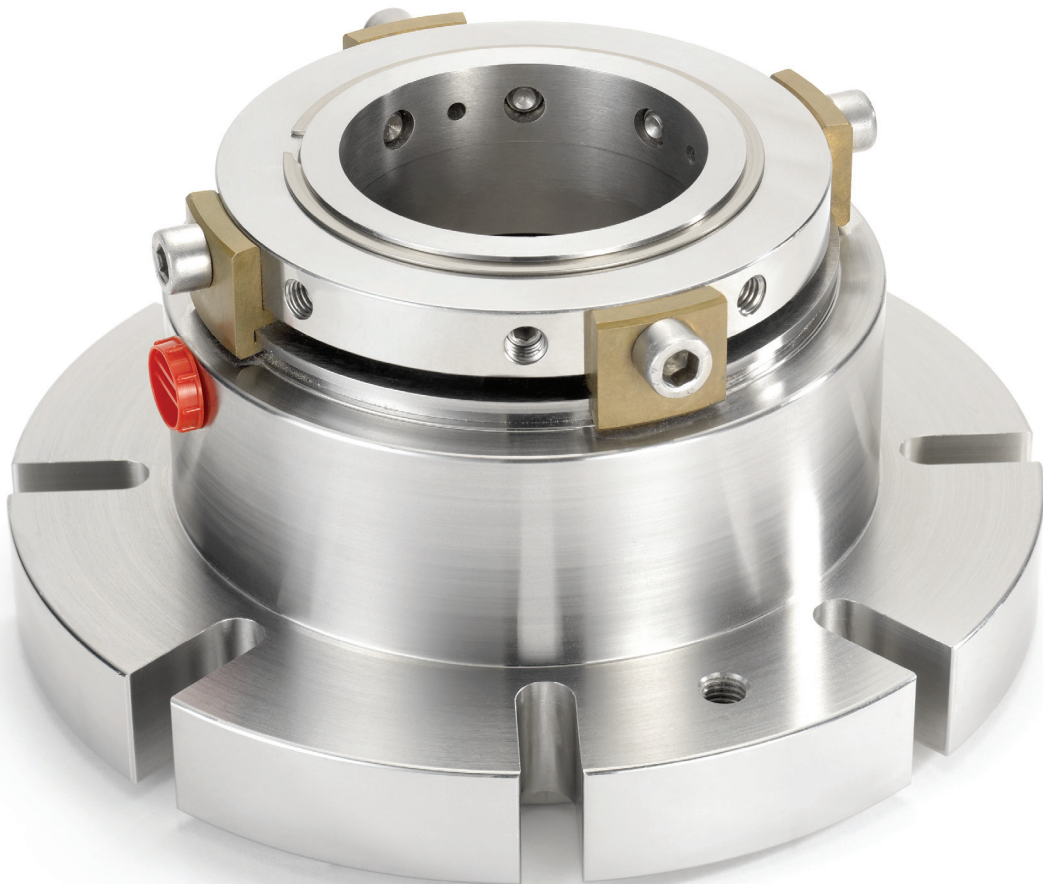

- Externally mounted cartridge seal
- Ability to accommodate axial and radial movement on mixer applications
- Integral cooling jacket
- Multi-port flush option
- Monolithic seal faces
- Exotic alloy wetted options

CDMSC™ - the optimum mixer seal without bearings

The CDMSC™ is designed specifically for Mixer, Agitator and Reactor applications.

This externally mounted cartridge seal has many features incorporated into the design to help increase seal life.

The CDMSC™ is based around the modular technology of the patented DMSF™, thereby making it both available and affordable.

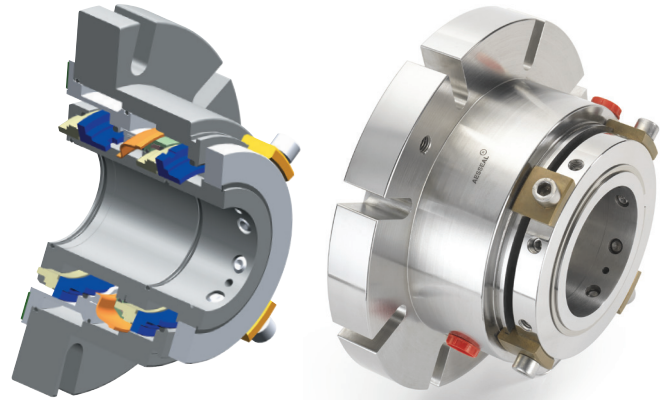

Radial Shaft Movement

Inevitably in most agitator applications, radial and / or axial shaft movement occurs.

Under slow shaft speed conditions, the CDMSC™ will accept moderate amounts of radial movement or Total Indicated Runout (TIR).

In any mechanical seal design, radial shaft movement is not preferred nor is it conducive to an optimum seal life.

Wherever possible this movement should be eliminated through the use of an appropriate equipment bearing arrangement. Alternatively, this movement could be eliminated through the selection of an appropriate seal with integral bearing such as a Mixmaster IV™, V™, VI™ or VII™.

Axial Shaft Movement

Reciprocating shaft movement as a consequence of upset conditions must be eliminated. For intentional reciprocating equipment an engineered seal design may be required, dependant on the application.

It is not uncommon to find thermal shaft growth in Agitator applications.

The CDMSC™ will accept moderate amounts of axial shaft movement from thermal growth. For shaft growth in excess of the stated figures, an alternate AESSEAL® design would be the preferred solution.

In such cases consult the AESSEAL® technical department.

Thermal Applications

As the CDMSC™ incorporates FOUR monolithic seal faces, the design has an excellent ability to seal thermally challenging applications.

It is important to note that when selecting a seal to operate in the vapour space of a top entry agitator, the temperature at the inboard seal faces could be approximately 70% of the process temperature.

- See AESSEAL® Gold Training Course for further information.

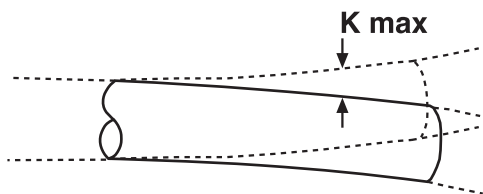
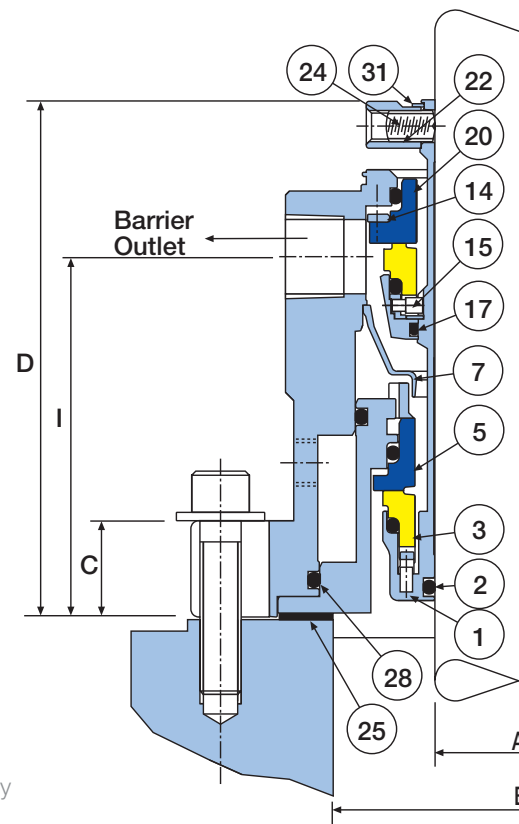

Axial shaft movement under thermal expansion conditions only	
Seal Size	Axial Movement
2.375" - 5.000"	+/- 0.040"
60mm - 125mm	+/- 1.0mm



CDMSC™ - dimensional information

Seal Sizes:- 2.375" - 5.000" (60mm - 125mm)

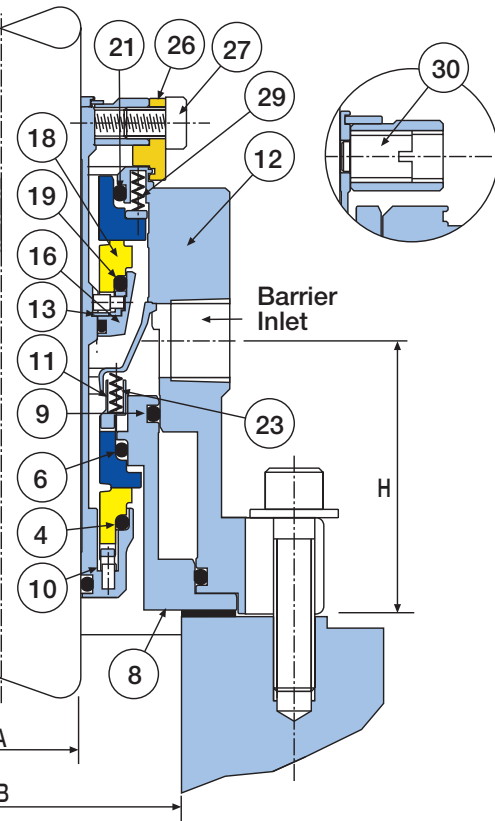
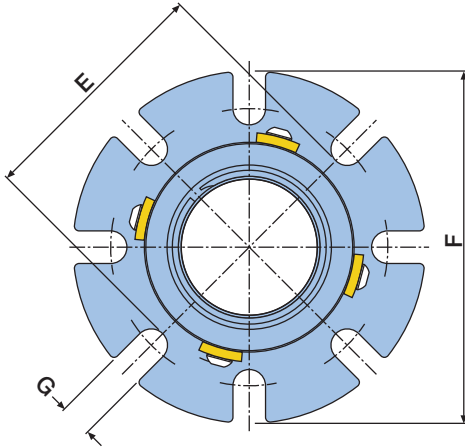

Seal Size	A	B Min	B Max	C	D	E	G (Qty.)	F	G	H	I	K (max)
60	60.0	85.0	133.0	36.8	122.6	154.0	8	210.0	14.0	67.2	83.7	6.0
65	65.0	90.0	139.0	36.8	122.6	154.0	8	210.0	14.0	67.2	83.7	6.0
70	70.0	95.0	139.0	36.8	122.6	154.0	8	210.0	14.0	67.2	83.7	6.0
75	75.0	100.0	139.0	36.8	122.6	156.0	8	219.0	14.0	67.2	83.7	6.0
80	80.0	105.0	165.0	36.8	127.0	189.2	8	261.0	14.0	67.2	83.7	6.0
85	85.0	110.0	165.0	36.8	127.0	189.2	8	261.0	14.0	67.2	83.7	6.0
90	90.0	115.0	190.5	36.8	127.0	212.7	8	261.0	14.0	67.2	83.7	6.0
95	95.0	120.0	190.5	36.8	127.0	212.7	8	261.0	14.0	67.2	83.7	6.0
100	100.0	125.0	190.5	36.8	127.0	212.7	8	261.0	14.0	67.2	83.7	6.0
105	105.0	130.0	203.2	36.8	127.0	233.5	8	273.0	14.0	67.2	83.7	6.0
110	110.0	135.0	203.2	36.8	127.0	233.5	8	273.0	14.0	67.2	83.7	6.0
115	115.0	140.0	222.2	36.8	127.0	259.0	8	305.0	14.0	67.2	83.7	6.0
120	120.0	145.0	222.2	36.8	127.0	259.0	8	305.0	14.0	67.2	83.7	6.0
125	125.0	150.0	222.2	36.8	127.0	259.0	8	305.0	14.0	67.2	83.7	6.0
2.375	2.375	3.375	5.236	1.447	4.829	6.063	8	8.260	0.551	2.647	3.294	0.236
2.500	2.500	3.500	5.236	1.447	4.829	6.063	8	8.260	0.551	2.647	3.294	0.236
2.625	2.625	3.625	5.472	1.447	4.829	6.063	8	8.260	0.551	2.647	3.294	0.236
2.750	2.750	3.750	5.472	1.447	4.829	6.063	8	8.260	0.551	2.647	3.294	0.236
2.875	2.875	3.875	5.472	1.447	4.829	6.063	8	8.260	0.551	2.647	3.294	0.236
3.000	3.000	4.000	5.472	1.447	4.829	6.142	8	8.620	0.551	2.647	3.294	0.236
3.125	3.125	4.125	6.500	1.447	5.000	7.449	8	10.276	0.551	2.647	3.294	0.236
3.250	3.250	4.250	6.500	1.447	5.000	7.449	8	10.276	0.551	2.647	3.294	0.236
3.375	3.375	4.375	6.500	1.447	5.000	7.449	8	10.276	0.551	2.647	3.294	0.236
3.500	3.500	4.500	6.500	1.447	5.000	7.449	8	10.276	0.551	2.647	3.294	0.236
3.625	3.625	4.625	7.500	1.447	5.000	8.375	8	10.276	0.551	2.647	3.294	0.236
3.750	3.750	4.7a50	7.500	1.447	5.000	8.375	8	10.276	0.551	2.647	3.294	0.236
3.875	3.875	4.875	7.500	1.447	5.000	8.375	8	10.276	0.551	2.647	3.294	0.236
4.000	4.000	5.000	7.500	1.447	5.000	8.375	8	10.276	0.551	2.647	3.294	0.236
4.125	4.125	5.125	8.000	1.447	5.000	9.193	8	10.750	0.551	2.647	3.294	0.236
4.250	4.250	5.250	8.000	1.447	5.000	9.193	8	10.750	0.551	2.647	3.294	0.236
4.375	4.375	5.375	8.000	1.447	5.000	9.193	8	10.750	0.551	2.647	3.294	0.236
4.500	4.500	5.500	8.000	1.447	5.000	9.193	8	10.750	0.551	2.647	3.294	0.236
4.625	4.625	5.625	8.750	1.447	5.000	10.197	8	12.000	0.551	2.647	3.294	0.236
4.750	4.750	5.750	8.750	1.447	5.000	10.197	8	12.000	0.551	2.647	3.294	0.236
4.875	4.875	5.875	8.750	1.447	5.000	10.197	8	12.000	0.551	2.647	3.294	0.236
5.000	5.000	6.000	8.750	1.447	5.000	10.197	8	12.000	0.551	2.647	3.294	0.236

* Check availability - most sizes are made to order only

Item	Description	Material
1	Sleeve	316L SS
2	Sleeve O Ring	Viton® / EPR / Kalrez® / Aflas®
3	Internal Rotary Face*	Carbon / SiC / TC
4	Internal Rotary Face O Ring	Viton® / EPR / Kalrez® / Aflas®
5	Internal Stationary Face*	SiC / TC
6	Internal Stationary Face O Ring	Viton® / EPR / Kalrez® / Aflas®
7	Deflector	316L SS
8	Gland Insert	316L SS
9	Gland Insert O Ring	Viton® / EPR / Kalrez® / Aflas®
10	Internal Drive Ring / Drive Pins*	316L SS
11	Internal Spring Plate	316L SS
12	Gland	316L SS
13	Circlip	Stainless Steel
14	External Spring Plate	316L SS
15	External Drive Ring / Drive Pins*	316L SS
16	External Rotary Holder	316L SS
17	External Rotary Holder O Ring	Viton® / EPR / Kalrez® / Aflas®
18	External Rotary Face*	Carbon / SiC / TC
19	External Rotary Face O Ring	Viton® / EPR / Kalrez® / Aflas®
20	External Stationary Face*	SiC / TC
21	External Stationary Face O Ring	Viton® / EPR / Kalrez® / Aflas®
22	Clamp Ring	316L SS
23	Internal Springs	Alloy 276
24	Drive Screws	Stainless Steel
25	Gasket	AF1 / GFT PTFE
26	Setting Clips	Zinc Alloy / Brass
27	Clip Screws	Stainless Steel
28	Gland Insert O Ring	Viton® / EPR / Kalrez® / Aflas®
29	External Springs	Alloy 276
30	Anti Tamper Screws	Stainless Steel
31	Circlip	Stainless Steel

*Size dependant features



CDMSC™ - better by design

The Importance of Correct Venting

If poorly vented, damage will occur to any mechanical seal face design, which is not designed for such "dry" running conditions.

Priming the seal faces is particularly important on vertical applications.

The CDMSC™ has a barrier outlet port positioned in such a manner as to correctly and reliably vent air from the barrier system.

Environmental Control

Often the most applicable solution to sealing difficult applications is to change the seal environment. The CDMSC™ design includes an integral cooling / heating jacket. This can be used to cool or heat the seal environment helping to extend seal life in difficult thermal applications.

Furthermore, the gland insert used to create the environmental jacket can be offered to include a multi-port flush option. This ensures equal circumferential seal face quenching helping to eliminate un-quenched areas.

Exotic Alloy Options

Occasionally the process media in a reactor is chemically aggressive.

The CDMSC™ can be offered with wetted parts supplied in any commercially available material. Standard materials offered include Alloy 276, Titanium, Alloy 255 and Alloy 400.

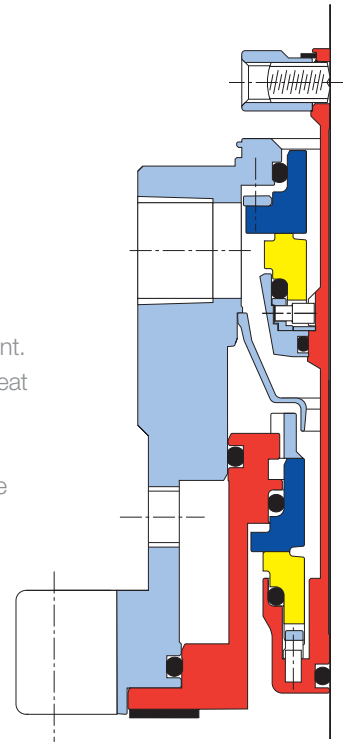

In addition to a vast range of mechanical seals, AESSEAL® has a specialized systems division, dedicated to the design and manufacture of a comprehensive range of seal support packages for double mechanical seals. These support systems range from Thermosyphon systems, SWFF-TF™, FLOWTRUE™ and AES-15™, to the fully featured forced circulation system PUMPPAC™ for use on oil and water applications.



SWFF-TF™



FLOWTRUE™



AES-15™



PUMPPAC™

The systems above are compatible with a wide selection of barrier and buffer fluid media. They are supplied pre-assembled with all necessary components and fittings. On-site inventory costs are reduced by modular system construction.

This document is designed to provide dimensional information and an indication of availability. For further information and safe operating limits contact our technical specialists at the locations below.



Use double mechanical seals with hazardous products.

Always take safety precautions:

WARNING

- Guard your equipment
- Wear protective clothing

UK Sales & Technical advice:

AESSEAL plc
Mill Close
Bradmarsh Business Park
Rotherham
S60 1BZ
United Kingdom

Tel: +44 (0) 1709 369966
Fax: +44 (0) 1709 720788
E-mail: seals@aessteel.com

Distributed by:

'Our purpose is to give our customers such exceptional service that they need never consider alternative sources of supply.'

www.aessteel.com

USA Sales & Technical advice:

AESSEAL Inc.
355 Dunavent Drive
Rockford
TN. 37853
USA

Tel: +1 865 531 0192
Fax: +1 865 531 0571
E-mail: usa@aessteel.com

Important: Since the conditions and methods of use of this product are beyond our control, AESSEAL plc expressly disclaims any and all liability resulting or arising from any use of this product or reliance on any information contained in this document - AESSEAL plc standard conditions of sale apply. All sizes are subject to manufacturing tolerances. We reserve the right to modify specifications at any time. AESSEAL® is a Registered Trademark of AESSEAL plc, AESSEAL plc recognizes all trademarks and trademark names as the property of their owners.